

322



# ATE 系列无线测温传感器

## ATE series Wireless Temperature Sensor

安装说明 V2.2

Installation Instruction V2.2

安科瑞电气股份有限公司  
Acrel Co., Ltd.

## 申 明

### DECLARATION

版权所有，未经本公司之书面许可，此手册中任何段落，章节内容均不得被摘抄、拷贝或以任何形式复制、传播，否则一切后果由违者自负。

本公司保留一切法律权利。

All rights reserved. No part of this publication may be reproduced, stored in a retrieval system, or transmitted in any form by any means, electronic, mechanical photocopying, recording, or otherwise without prior permission of our company. The violator will bear the dependent legal responsibility.

We reserve all the rights.

本公司保留对本手册所描述之产品规格进行修改的权利，恕不另行通知。

订货前，请垂询当地代理商以获悉本产品的最新规格。

We reserve all the rights to revise product specification without notice. Please consult local agent to get the latest information of our products specification.

# 目 录

## Contents

ATE 系列无线测温传感器 .....	1
ATE series Wireless Temperature Sensor .....	1
安科瑞电气股份有限公司 .....	1
1 安装指南 .....	1
1 Installation Guide .....	1
1.1 产品概述 .....	1
1.1 Product Introduction .....	1
1.2 型号说明 .....	1
1.2 Type Introduction .....	1
1.3 技术指标 .....	2
1.3 Technical Features .....	2
1.4 产品安装 .....	4
1.4 Product Installation .....	4

# 1 安装指南

## 1 Installation Guide

### 1.1 产品概述

#### 1.1 Product Introduction

ATE 系列无线测温传感器根据 《NB/T 42086-2016 无线测温装置技术要求》 开发，可用于 3~35kV 户内开关柜，包括中置柜、手车柜、固定柜、环网柜等多种开关柜；也可用于 0.4kV 低压柜，包括固定柜，抽屉柜等。无线测温传感器可安装于柜内任何发热点上，利用无线数据传输技术实时发送监测数据，再通过接收装置将温度数据传输到显示装置或者远程监控系统。

ATE series wireless temperature measuring sensor has been developed in compliance with *Specification for Wireless Temperature Measuring equipment, NB/T 42086-2016*. It is suitable for 3-35kV indoor switchgears, including built-in switchgears, handcart switchgears, fixed switchgears and loop-net switchgears. It is also suitable for 0.4kV low-voltage switchgears such as fixed switchgears and drawer switchgears. The wireless temperature sensors can be installed at any heating point in switchgears, the device utilizes the wireless data transmission technology for real-time transmission of monitored temperature data. In addition, it can be transmitted to display device or remote intelligent monitoring system.

### 1.2 型号说明

#### 1.2 Type Introduction

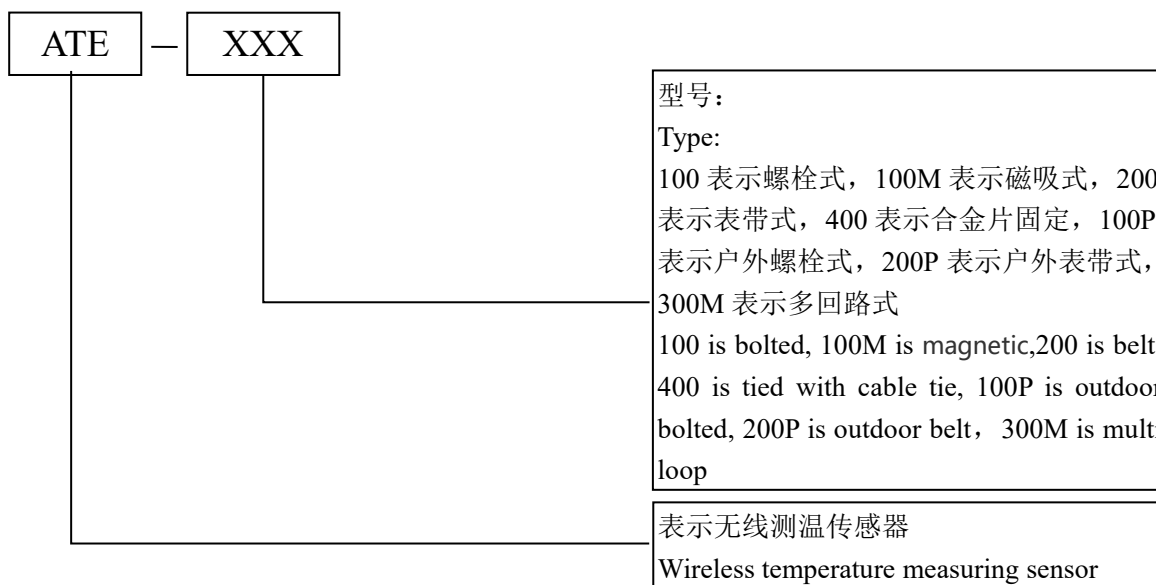

## 1.3 技术指标

## 1.3 Technical Features

项目 Items		指标 Features
环境要求 Environment	工作温度 Temperature	-40℃~85℃
	相对湿度 Humidity	≤95%
	大气压力 atmospheric pressure	86kPa~106kPa
ATE100M/100/200 有源无线温度传感器 ATE100M/100/200 Active wireless temperature sensor	无线频率 Wireless frequency	470MHz、433Mhz
	通讯距离 Communication distance	空旷 150m (470Mhz)、空旷 50m (433Mhz) 150m(470Mhz)、50m(433Mhz)in open area
	采样频率 Sampling frequency	25s
	发射频率 Transmitting frequency	25s-5min
	工作电源 Power source	电池 Battery
	安装方式 Installation	磁吸式/螺栓式/表带式 Magnetic / bolted /Belt
	测温范围 Range of temperature	-50℃~+125℃
	精度 Precision	±1℃
	应用范围 Application	高低压柜内电气接头 Joints in high or low voltage switchgears
	电池寿命 Battery life	≥5年(25℃) ≥5 years(25℃)
400 无源无线温度 传感器 400 Passive wireless temperature sensor	无线频率 Wireless frequency	470MHz、433Mhz
	通讯距离 Communication distance	空旷 150m (470Mhz)、空旷 50m (433Mhz) 150m(470Mhz)、50m(433Mhz)in open area
	采样频率 Sampling frequency	15s
	发射频率 Transmission frequency	15s
	工作电源 Power source	CT 感应取电, 启动电流≥5A CT-powered, starting current≥5A 最大工作电流(Max current)≤5000A

	安装方式 Installation	合金片固定 alloy chip fixing
	传感器探头 Sensor probe	合金底座 alloy bottom
	测温范围 Range of temperature	-50℃~125℃
	精度 Precision	±1℃
	应用范围 Application	高低压柜内电气接头 Joints in high or low voltage switchgears
ATE100P/200P 户外无线温度传感器 ATE100P/200P Outdoor wireless temperature sensor	无线频率 Wireless frequency	470MHz、433Mhz
	通讯距离 Communication distance	空旷 150m (470Mhz)、空旷 50m (433Mhz) 150m(470Mhz) 、50m(433Mhz)in open area
	采样频率 Sampling frequency	25s
	发射频率 Transmitting frequency	25s-5min
	工作电源 Power source	电池 Battery
	安装方式 Installation	螺栓式/表带式 bolted /Belt
	测温范围 Range of temperature	-50℃~+150℃
	精度 Precision	±0.5℃
	应用范围 Application	电气接头 Voltage switchgears
	电池寿命 Battery life	≥5 年(25℃) ≥5 years(25℃)
	防护等级 Protection level	IP68
ATE300M 多回路式温度传感器 ATE300M multi Loop temperature sensor	无线频率 Wireless frequency	433-510MHz
	通讯距离 Communication distance	空旷 1000m 1000m in open area
	采集频率 Sampling frequency	1-240s
	工作电源 Power source	AC/DC 85~265V
	安装方式 Installation	导轨式/扎带式
	测温范围 Range of temperature	-40℃~+140℃

	精度 Precision	$\pm 1^{\circ}\text{C}$
	应用范围 Application	低压抽屉柜内电气接头 Joints in low voltage switchgears

## 1.4 产品安装

### 1.4 Product Installation

无线温度传感器共有多种型号，分别对应磁吸固定、螺栓固定、表带固定、合金片固定等安装方式。

There are several types of wireless temperature sensors and mounting methods correspondingly, i.e. Magnetic , bolted , belt and alloy chip fixing.

#### 1.4.1 外形尺寸

#### 1.4.1 Shape Size

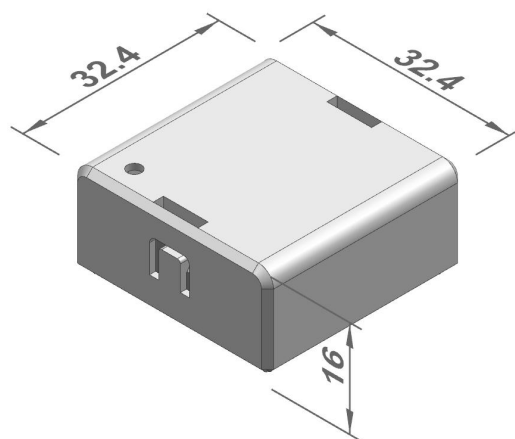

ATE100M

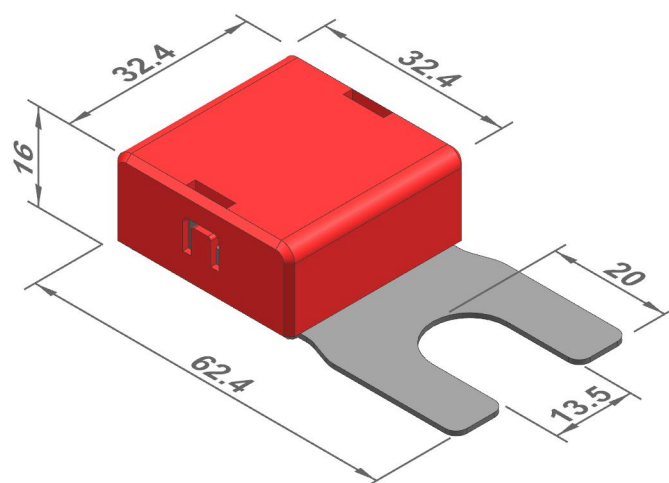

ATE100/ATE100P

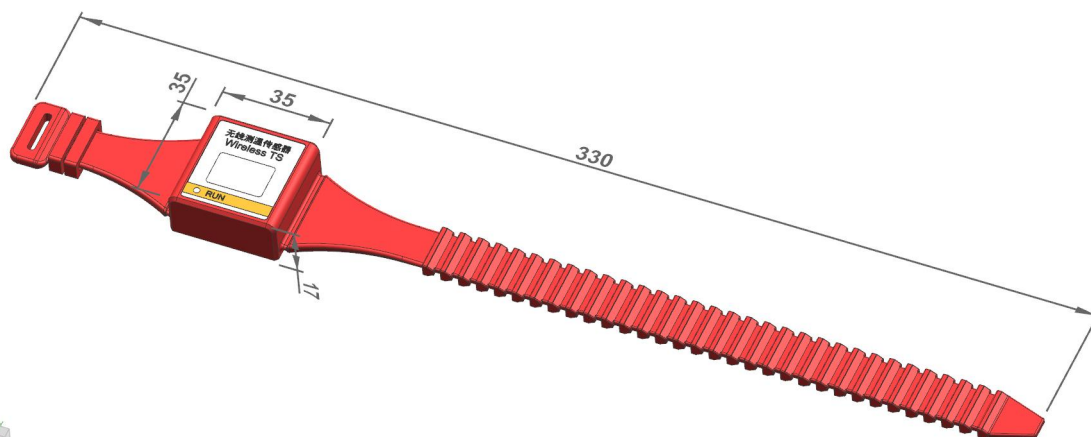

ATE200/ATE200P

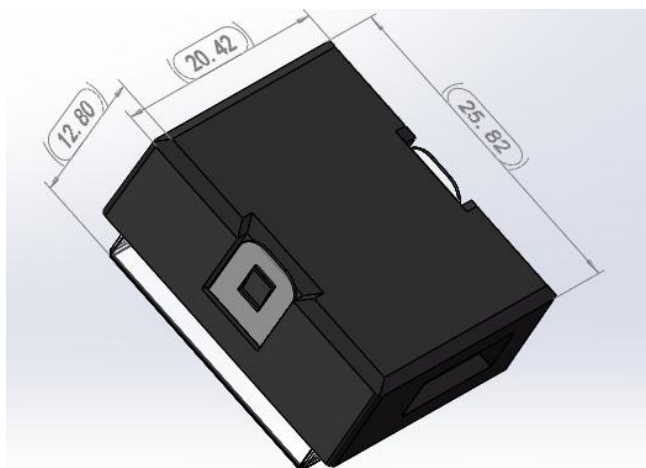

ATE400

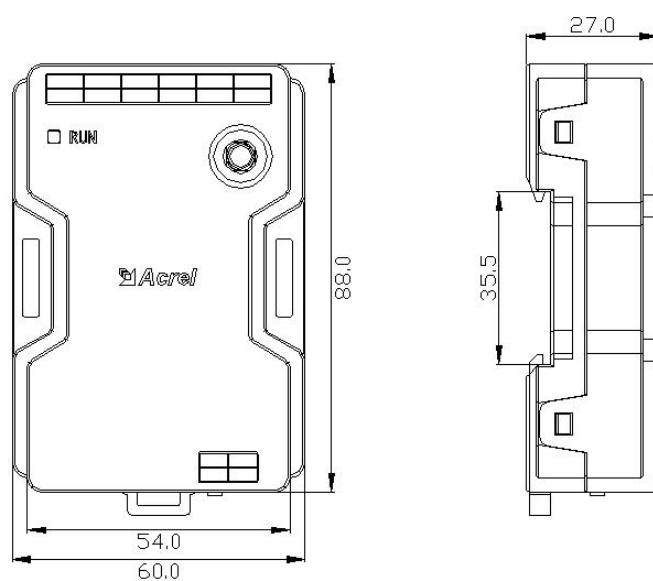

ATE300M



## 1.4.2 标签说明

### 1.4.2 Label Instructions

#### 1.4.2.1 ATE 传感器搭配 ASD/ARTM-Pn 装置

#### 1.4.2.1 ATE sensor with ASD/ARTM-Pn device



ASD/ARTM-Pn



ATE100M



ATE100



ATE200



ATE400



ATE100P



ATE200P

如果安装 ATE100M/ATE100/ATE200/ATE400/ATE100P/ATE200P，其组号应与显示装置 ASD/ARTM-Pn 的标签组号一致，安装位置依照标签文字安装，“编码：1A”为安装第一个 A 相，“编码：1B”为安装第一个 B 相，以此类推。

If the sensor is ATE100M/ATE100/ATE200/ATE400/ATE100P/ATE200P, the number behind “组号 (Group):” should be the same as ASD/ARTM-Pn, the sequence of installation is base on the label, “编码 (Code) : 1A” is first one on the phase A, “编码 (Code) : 1B” is first one on the phase B, and so on.

**注意：出厂时包装箱内无线温度传感器与显示装置已配对，不可以与其他显示装置或无线温度传感器混用，无线温度传感器按照标签安装。**

**Notice: wireless temperature sensors and display device in the package have been matched before delivery. Do not use them with other display device or other wireless temperature sensors together. Please installing them with label on the sensor.**

#### 1.4.2.2 ATE 传感器搭配 ATC600-C/ATC450-C 收发器

#### 1.4.2.2 ATE sensor with ATC600-C/ATC450-C coordinator



ATC600-C



ATC450-C



ATE100M



ATE100



ATE200



ATE400



ATE100P



ATE200P

如图所示，如果安装 ATE100M/ATE100/ATE200/ATE400/ATE100P/ATE200P，其组号应与 ATC450-C/ATC600-C 的组号一致，安装位置依照标签文字安装，“**编码：001**”建议安装在第一个柜子的第一个测温点，再依次按照测温点顺序安装。

According to the above pictures, If the sensor is ATE100M/100/200/400/100P/200P, the group number of ATE must be same as the group number of ATC450-C/ATC600-C and the installation order is base on the label. The code of each sensor is used to distinguish each sensor from same group. “**编码 (code): 001**” is recommended to be installed on the first temperature measuring point of the first cabinet, and then installed other sensors in this order.

#### 1.4.2.3 ATE300M 传感器搭配 ATC600-M 收发器

#### 1.4.2.3 ATE300M sensor with ATC600-M coordinator



ATE600-M



ATE300M

如果安装 ATE300M 传感器，其组号应与 ATC600-M 的组号一致，安装位置依照标签文字安装，“**编码：001**”建议安装在第一个柜内，再依次按照测温点顺序安装。

If the sensor is ATE300M, the group number of ATE must be same with the group number of ATC600-M and the installation order is base on the label. The code of each sensor is used to distinguish each sensor from same group. “**编码 (code) : 001**” is recommended to be installed on the first cabinet, **若有特殊情况，请联系相关工程师进行沟通解决。**

**In case of any special situation, please contact the relevant engineers for communication.**

### 1.4.3 安装方法

#### 1.4.3 Installation Method

##### 1.4.3.1 ATE100M 安装方法

##### 1.4.3.1 ATE100M Installation Method

ATE100M 磁吸式无线测温传感器适用于铁质的电气节点或设备表面。

The magnetic wireless sensor ATE100M is suitable for iron electrical nodes or equipment surfaces.

磁吸式无线温度传感器 ATE100M 结构说明：

Structure introduction of ATE100M:

1 —— 无线温度传感器主体 The core of wireless temperature sensor ATE100M

2 —— 测温部位 Thermo-sensitive part

3 —— 电池开关 battery switch

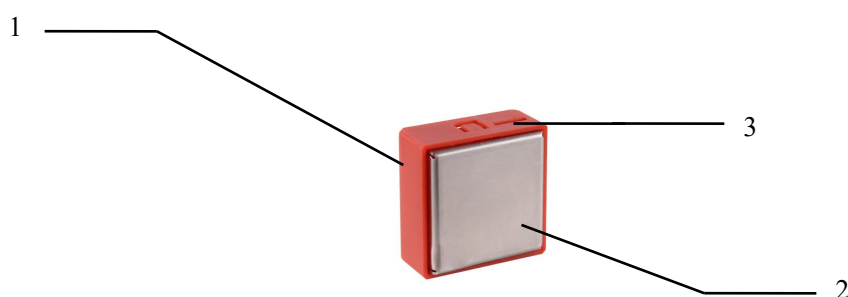

直接吸附在铁质测温点处，安装前打开电池开关，电源指示灯闪烁两次。安装实例见下图：

Adsorbed directly at the iron temperature measuring point, open the battery switch before installation, the power indicator flashes twice. The installation examples see images below.

##### 1.4.3.2 ATE100 安装方法

##### 1.4.3.2 ATE100 Installation Method

ATE100 螺栓式无线测温传感器适用于电缆与母排搭接处，电缆与隔离刀闸搭接处。

The bolted type wireless sensor ATE100 is suitable for use at joints between cable and bus bar and joints between cable and disconnecter.

ATE100 螺栓式无线温度传感器结构说明：

ATE100 structure introduction:

1 —— 无线温度传感器主体 The core of wireless temperature sensor ATE100

2 —— 测温部位 Thermo-sensitive part

3 —— 电池开关 battery switch

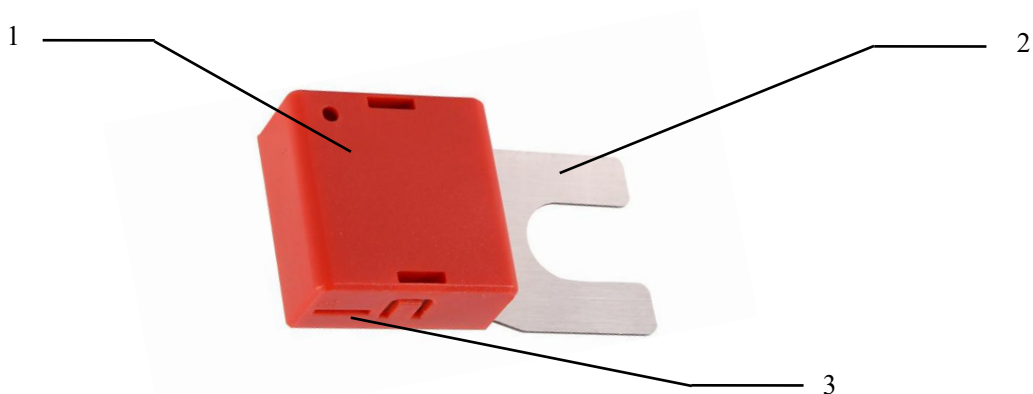

拆下安装位置搭接处的螺丝，将传感器固定在安装位置，对准合金底板的开孔，然后旋紧螺丝固定，安装前打开电池开关，电源指示灯闪烁两次。安装实例见下图：

Remove the screw from the joints, and fixing the sensor on the position with the hole on the alloy baseplate, then tighten the screw, open the battery switch before installation, the power indicator flashes twice. The installation examples see images below.

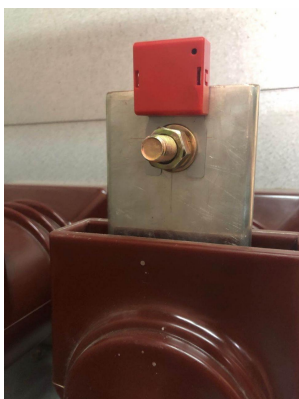

#### 1.4.3.3 ATE200 安装方法

#### 1.4.3.3 ATE200 Installation Method

ATE200 表带式无线测温传感器适用于断路器动触头、静触头、电缆接头、母排等处。

The strap-secured type called ATE200 is suitable for use at moving contacts and fixed contacts of breaker, cable joints and bus bar.

表带式无线温度传感器结构说明：

ATE200 structure introduction:

1 —— 无线温度传感器主体，测温探头在背面 The core of wireless temperature sensor ATE200, temperature measuring probe is on the other side

2 —— 表带及锁扣 strap and hasp

3 —— 电池开关 battery switch

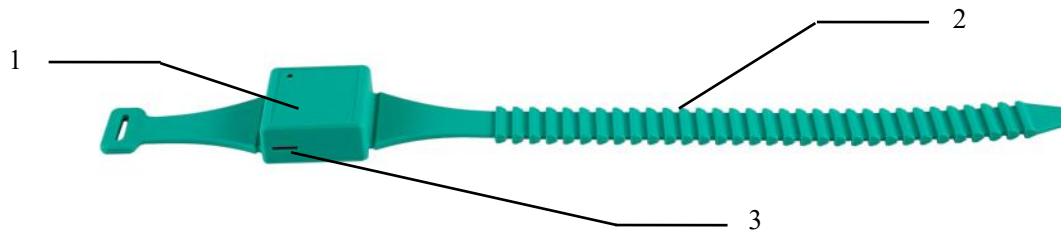

将传感器主体固定在安装位置，将表带绕过安装母排或者触头穿过表带，表带头收紧，最后将表带尾用锁扣锁紧。表带过长可以剪掉多余部分，表带过短可以联系我司增订。安装前打开电池开关，电源指示灯闪烁两次。安装实例见下图：

**注：ATE200 可安装静触头，铜排，电缆头。**

Fixing the body of sensor on the position, then strapping it on the bus bar or breaker contact and frapping it through the hole on the strap, fixing the strap by hasp. Clipping the strap if it is too long when finished, if it is too short, contacting us for strap parts before installation. Open the battery switch before installation, the power indicator flashes twice. The installation examples see images below.

**Note: ATE200 can be installed with fixed contact, copper plate and cable head.**



#### 1.4.3.4 ATE400 安装方法

#### 1.4.3.4 ATE400 Installation Method

ATE400 迷你型无线温度传感器适用于动触头，母排，电缆，母排、电缆搭接处等多种场合。

The mini type called ATE400 is suitable for using at moving contacts, bus bars, cables and joints between bus bar and cable.

迷你型无源无线温度传感器结构说明：

Mini type passive temperature sensor structure introduction:

- 1 —— 温度传感器主体 The core of wireless temperature sensor ATE400
- 2 —— 合金底座，与温度探头接触 alloy bottom, touched with temperature probe
- 3 —— 锁扣，用于固定合金片 metal hasp, for fixing alloy chip
- 4 —— 取电合金片，用于感应取电 alloy chip, for CT-powered
- 5 —— 硅胶垫片，用于支撑合金片 silicone gasket, used to support the alloy chip
- 6 —— 合金片安装孔，用于安装合金片 alloy chip hole, used to install the alloy chip

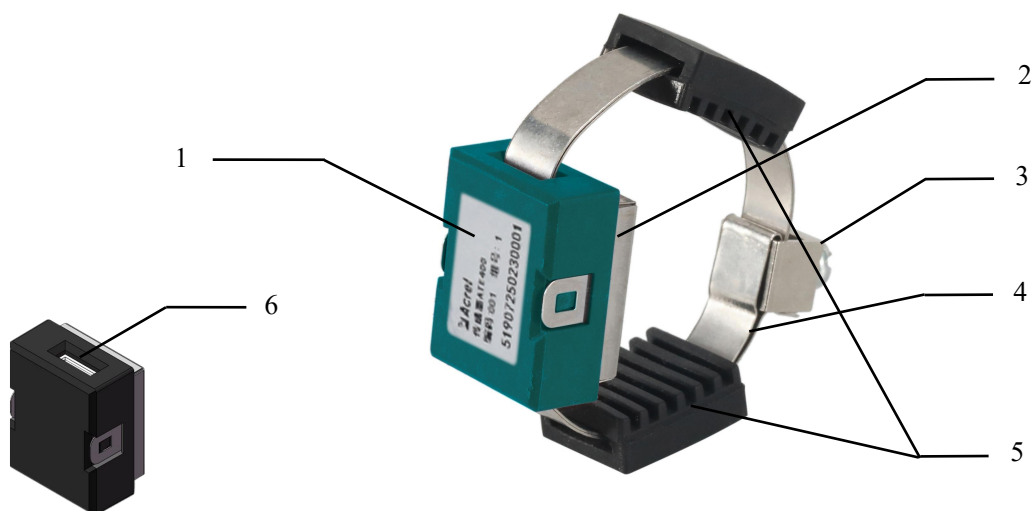

取 2 根合金片穿过锁紧件安装孔，将合金片居中对折后锁紧件固定在折弯处；将对折后的 4 层合金片分别穿过硅胶垫片-传感器主体-硅胶垫片；将整体传感器环绕安装部位一圈后拉紧合金片并旋紧螺丝；合金片多余部分留取适当长度并折叠压紧。合金片安装示意过程如下：

**注：ATE400 可安装静触头，铜排，电缆头；如需安装动触头，需要考虑梅花头及套筒高度是否足够。**

Firstly, take 2 pieces of alloy chips through the mounting hole of metal hasp, meanwhile fold the alloy chips and fix the metal hasp in the middle of alloy chips. Secondly, take the folded alloy chips through one silicone gasket, the core of ATE400 and another silicone gasket in turn. Thirdly, circle the whole alloy chips around the mounting position and tension the alloy chips, then tighten the screw on the metal hasp. Finally, subtract the excess alloy chips. The complete installation process is shown in Figures 1 to 4.

**Note: ATE400 can be installed with fixed contact, copper plate and cable head; If it is necessary to install moving contacts, it is necessary to consider the height of plum blossom head and sleeve is sufficient.**

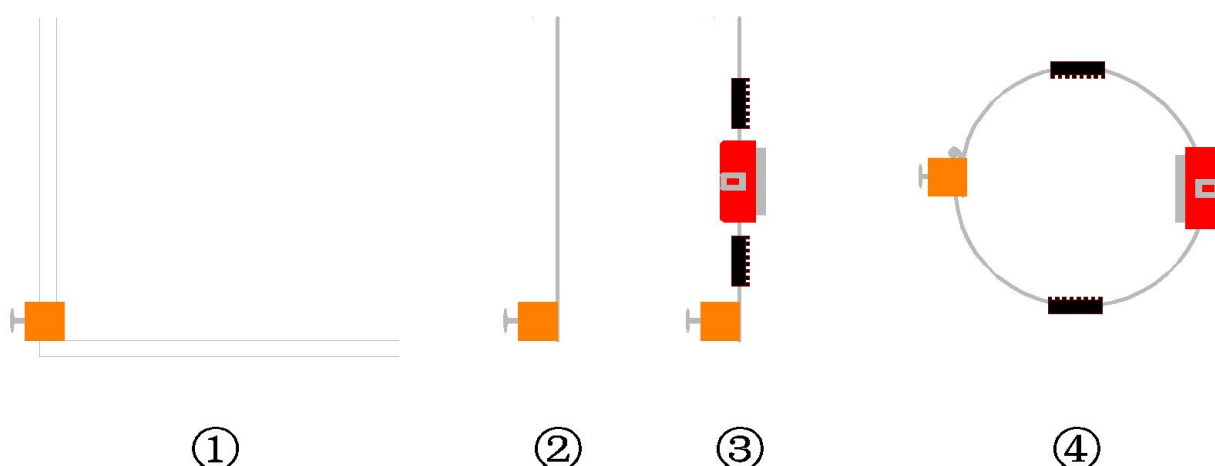

ATE400 无线温度传感器安装实例如下：

The wireless temperature sensor called ATE400 installation examples, see images below.

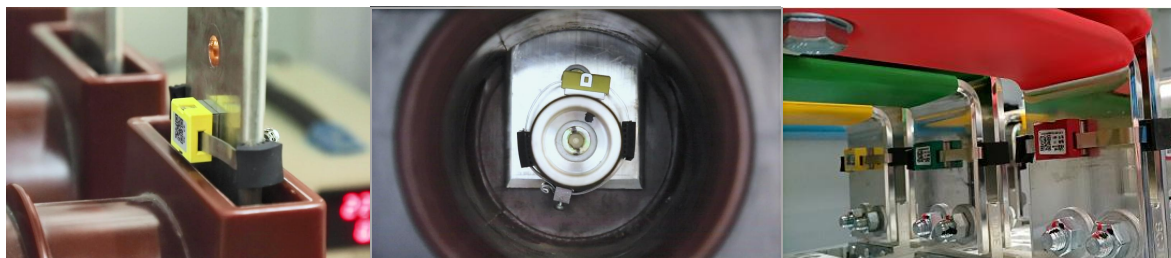

#### 1.4.3.5 ATE300M 安装方法

#### 1.4.3.5 ATE300M Installation Method

ATE300M 多回路式温度传感器适用于低压柜内电气接头等多种场合。

Ate300M multi circuit temperature sensor is applicable to various occasions such as electrical connectors in low-voltage cabinet.

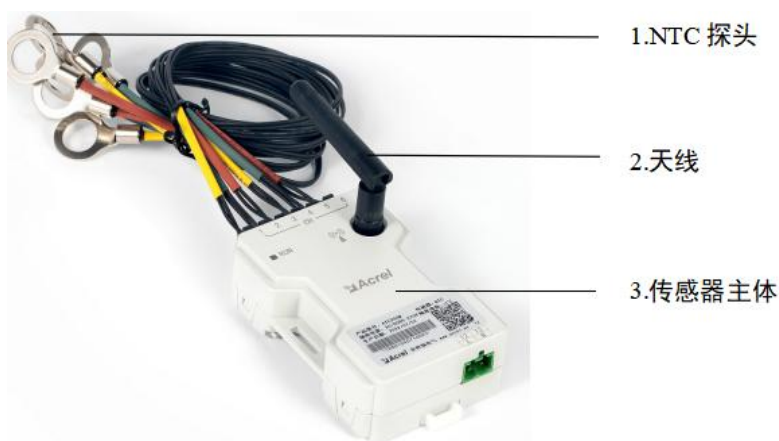

将传感器主体在柜内合适位置通过导轨或者扎带捆绑的方式固定好，拆下安装位置搭接处的螺丝，将 NTC 探头套入接头位置，然后旋紧螺丝固定。用 AC/DC 85~265V 电源给传感器供电，上电时电源指示灯红灯闪烁 2 次。

Fix the sensor body at the proper position in the cabinet by means of guide rail or binding tape, remove the screws at the overlapping position of the installation position, put the NTC probe into the joint position, and then tighten the screws for fixation. Use AC / DC 85 ~ 265V power supply to supply power to the sensor. The red light of the power indicator flashes 2 times when the power is on .

Headquarters: Acrel Co., LTD.

Sales engineer: Augustus Yang

Address: No.253 Yulv Road Jiading District, Shanghai, China

Mobile/Whatsapp/Wechat: +86 136 1197 6994

Skype: rayyang11081

Website: [www.acrel.sg](http://www.acrel.sg)

Email: [augustus@acrel.cn](mailto:augustus@acrel.cn)

Postcode: 201801