



AHE wireless temperature and humidity sensor

Installation V1.0

Acrel Co., Ltd.

1 Installation guide

1.1 Overview

AHE 无线温湿度传感器主要用于中高压开关柜、端子箱、环网柜、箱变等设备内部温度和湿度的检测。该模块采用专用外壳，通风效果好，外观精致，既能有效保护内部元件，提高使用寿命，又方便安装、接线。

AHE wireless temperature and humidity sensor is mainly used for the detection of internal temperature and humidity in medium and high voltage switch cabinets, terminal boxes, ring network cabinets, box transformers and other equipment. The module adopts a special shell, which has good ventilation effect and exquisite appearance, which can effectively protect the internal components, increase the service life, and is convenient for installation and wiring.

1.2 技术指标 Technical index

技术参数 Parameters		指标 Value
测量范围 Measurement range	温度 Temperature	-30℃~+85℃
	湿度 Humidity	10~99%RH
精度 Accuracy	温度 Temperature	±1℃
	湿度 Humidity	±3%RH
发射频率 Transmit frequency		5min
通讯接口 Communication Interface		RS485, MODBUS (RTU) 协议 RS485, MODBUS (RTU) protocol
传输距离Transmission distance		200m
电池寿命Battery life		≥3 years 年 (可更换changable)
安装方式Installation		导轨式 Din rail installation

1.3 产品安装 The product installation

AHE 无线温湿度传感器，采用导轨（DIN35mm）安装方式，使用前需打开电池开关。

The AHE wireless temperature and humidity sensor adopts the guide rail (DIN35mm) installation method, and the battery switch needs to be turned on before use.

- 1 —— 无线温湿度传感器主体 Wireless temperature and humidity sensor main body
- 2 —— 电池开关 Battery switch

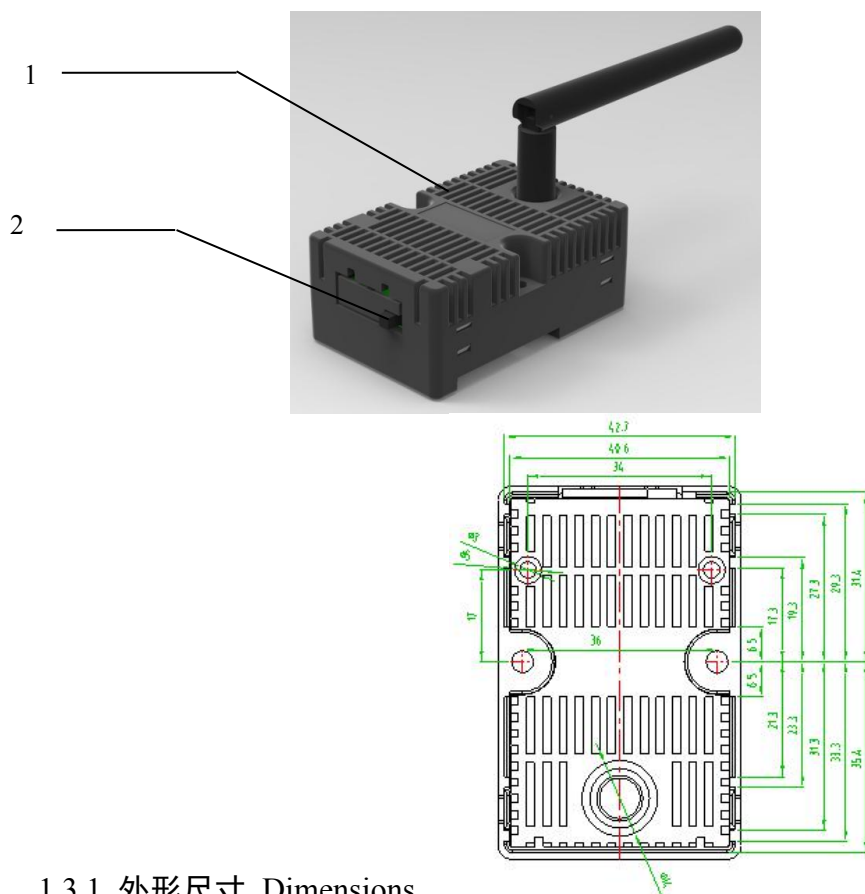

1.3.1 外形尺寸 Dimensions

图 1.1 温湿度传感器

Figure 1.1 Temperature and humidity sensor

1.4 无线温湿度传感器收发器 Wireless temperature and humidity sensor transceiver

与 AHE 无线温湿度传感器配套使用的无线温度收发器 ATC600，可以采用导轨（DIN35mm）安装方式。

The wireless temperature transceiver ATC600 used with the AHE wireless temperature and humidity sensor can be installed on a rail (DIN35mm).

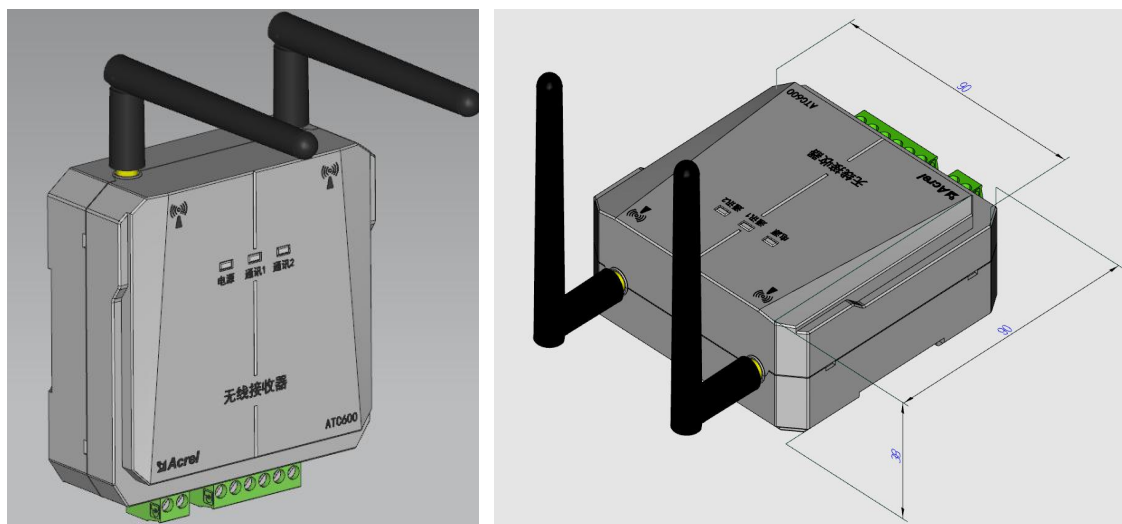

1.5 方案配置 Scheme configuration

触摸屏搭配 ATC600-C:

Touch screen with ATC600-C:



说明：触摸屏通过 RS485 接口连接一只 ATC600-C 实现开关柜温湿度集中显示，一只 ATC600-C 可接收 240 只温湿度传感器。

Note: The touch screen is connected to an ATC600-C through the RS485 interface to realize the centralized display of the temperature and humidity of the switch cabinet, and each ATC600-C can receive 240 temperature and humidity sensors.

Headquarters: Acrel Co., LTD.

Sales engineer: Augustus Yang

Address: No.253 Yulv Road Jiading District, Shanghai , China

Mobile/Whatsapp/Wechat: +86 136 1197 6994

Skype: rayyang11081

Website: www.acrel.sg

Email: augustus@acrel.cn

Postcode: 201801